

21

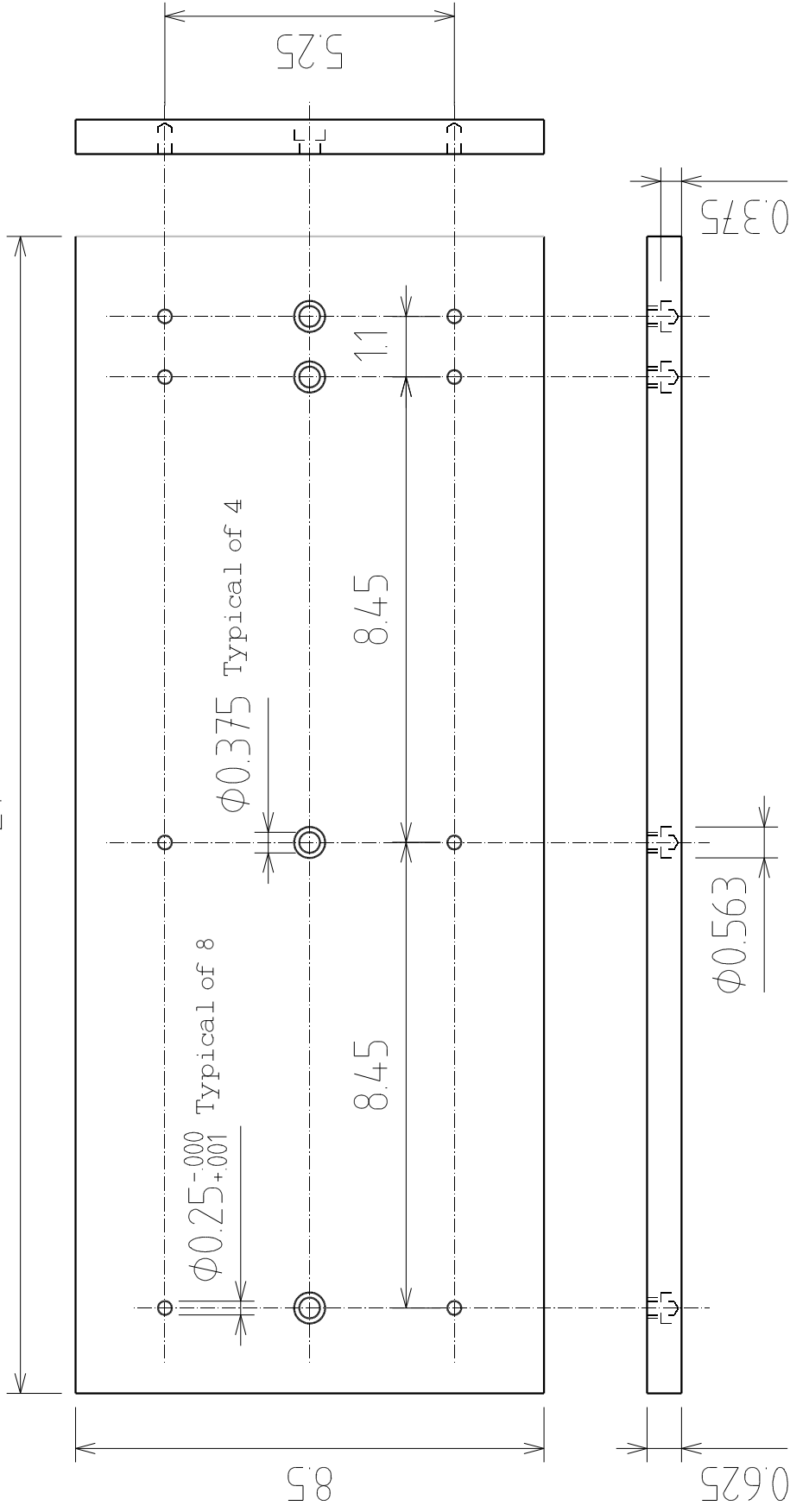

Notes:

Material is Aluminum 6061-T6 or similar
Plate thickness in not critical

The eight 1/4 inch holes are for locating pins which are intended to be removed and inserted by hand, or with gentle tapping

1/4 inch holes should NOT be reamed through (Despite the drawing, it's OK, and probably desirable to drill through approximately 0.01 inches undersize)

1/4 inch holes should be reamed to a depth such that 1/4 inch diameter locating pins can be inserted about 1/2 inch before bottoming out

The holes for the four holding bolts are counterbored from the bottom to recess the bolt heads. The counterbore dimensions given are minimum requirements.

